

Review Article

A Comprehensive Review on Buck–Boost Integrated Control Strategies for Cascaded PV Inverter Systems under Variable Irradiation and Unbalanced Grid Conditions

Mohamed Emadeldin Mohamed Awadalkarem¹, Priyanka Maheshwari², Abhimanyu Kumar³

¹Scholar, ²Assistant Professor, ³Associate Professor, Department of Electrical Engineering, RKDF University, Bhopal India

I N F O

Corresponding Author:

Mohamed Emadeldin Mohamed
Awadalkarem, Department of Electrical
Engineering, RKDF University, Bhopal India

E-mail Id:

memad8145@gmail.com

Orcid Id:

<https://orcid.org/0009-0002-4305-7026>

How to cite this article:

Awadalkarem M E M, Maheshwari P, Kumar A, A Comprehensive Review on Buck–Boost Integrated Control Strategies for Cascaded PV Inverter Systems under Variable Irradiation and Unbalanced Grid Conditions. *J Adv Res Instru Control Eng* 2026; 13(1&2): 1-10.

Date of Submission: 2025-11-22

Date of Acceptance: 2025-12-23

A B S T R A C T

With the rapid integration of photovoltaic (PV) systems into modern power networks, the need has increased for power converters whose efficiency is high enough that they can remain stable with fluctuating irradiance and temperature variations as well as unbalanced loading conditions. Their standard single-stage evidences a lack of voltage regulation which, in turn, results in imperfect power extraction and unnecessary elevated harmonic distortion. It further discomfort scales grid stability. The paper reviews the progress of the technology, challenges faced, and innovations of PV inverter control with an accentuated exploration aiming at buck-boost control integrated by cascaded and per-phase distributed inverter structures. Research from 2021 to 2025 has shown a change of focus toward the development of intelligent converter designs, algorithm projects for adaptiveness, coordinating DC-DC/DC-AC operations for system performance enhancement. The review amalgamates with the results from studies regarding dual-iteration-based modeling, hybrid metaheuristic optimization (HJAYADE, POA, ITSA), dynamic fractional order modeling, AI-based irradiance forecasting, and advanced MPPT techniques (fuzzy logic, MSSA-optimized controllers, MPC, and deep learning). Further improvements manifested include significantly reduced RMSE in PV parameter estimation, an MPPT tracking efficiency of more than 99%, a THD rate below 1% for currents and voltages, and perhaps noticeable active power increases in grid-interconnected cases. Among advantages rendered are the superiority of DC-link regulation, tolerance to a module-level mismatch, and reactive power support. However, a series of drawbacks are evident-such as dynamic validation, hardware scalability, environmental generalizability, and computational burden for intelligent methods. This paper gets the entire overview of the existing technologies, identifies research gaps, and points to the necessity of a unified approach in control architecture that combines DC-DC regulation, multilevel DC-AC conversion, and real-time intelligent optimization. Such advances help envisage next-generation resilient PV inverters for smart grid and high-penetration renewable energy.

Keywords: Buck–Boost Control, Cascaded PV Systems, MPPT, Grid Integration, THD Reduction, Distributed Inverters, Irradiance Variability, Optimization Algorithms, Renewable Energy Systems

Introduction

Among the many drivers of the energy renewable thrust is the need to preserve the environment, besides having a contravening effect on energy sustainability. The environmentalist agenda has probably acted as a faster propeller for the accelerating introduction of photovoltaic (PV) systems across the globe. PV solar systems represent clean and inexhaustible resources. One lively focus of modern power system research is to integrate these systems with the grid.¹ Yet insolation's intermittent behavior and its ever-recurring variability problematize a consistent power output. The variations in the DC link voltage and inverter output frequently lead to disrupted-percentages that lay adverse effects on the quality of 'grid-friendly power'.²

Bloomingly popular in connected organizations of photovoltaic systems, cascaded multilevel inverters, especially cascaded full-bridge-based inverters, are significantly scalable, enjoy outstanding power quality, and provide modularity.¹ Unlike their conventional counterparts, the cascaded multileveled inverters can produce superimposed wave inversions with very low total harmonic distortion (THD) levels and, thus, suitable for medium- and high-voltage grids.³ These imbalances are the source of several performance issues without support, as different from the perfect matching of module characteristics, shadowing, and lower illumination onto the different photovoltaic subarrays, resulting in different levels of charging voltage which are inconsistent across inverters.⁴ These unbalances, besides reducing the efficiency of the system as a whole, contribute to harmonic distortions and additional losses to the electronic power component.

Namely, buck-boost DC-DC converters have recently been adopted in photovoltaic (PV) inverter systems for controlling the voltage fluctuations for each sub-array and for intensifying energy acquisition. The buck-boost converter allows either step-up or step-down conversion of DC voltage so as to position each PV module closer to its maximum power point while facing various irradiances.⁵ Whereas effective cascading of the buck-boosted converters to the inverters for voltage balancing amongst inverter cells is greatly improving its dynamic mode, the power oscillations can be curtailed. However, it implies increased system complexity; hence, only in an advanced control technique can the act of coordinating the operation of multiple inverters be achieved.⁶

Another significant challenge for solar-powered systems occurs when the system is working under various grid conditions. Typical modes of such grid conditions include unbalanced grid vocations due to asymmetric loads, faults,

or grid disturbances. Therefore, the unbalancing of systems is a phenomenon confronted when trying to deliver essential services to the load. Under these unbalanced conditions, the quality of power becomes degraded by the unbalanced component of the magnetic field, which may result in harmonic currents and switch damages of the inverter.⁷ In conclusion, appropriate control strategies are needed to propose an excellent solution not only to swiftly manage DC-link voltage fluctuations due to irradiance variability but also to protect the inverter from unbalanced grid conditions.⁸

A few control strategies, including conventional proportional-integral (PI) controllers, predictive control, and advanced model-based approaches, have been proposed in the literature.⁹ These aim at maintaining a constant voltage at the DC link, tracking the maximum power point, suppressing harmonics, and compensating for unbalance at the grid. Although there have been significant advances, a significant bottleneck still exists in developing a control algorithm that takes the instantaneous variation in the irradiance, unbalance in DC-link voltage, and grid unbalance into account and ensures high efficiency with low total harmonic distortion.

This review article assesses an unqualified view of cutting edge buck-boost integrated control schemes toward the cascaded inverter in a PV system, considering variable irradiation and unbalanced grid conditions. The aim of this review process is to perhaps have a synthetic summary on any conventional approaches, and perhaps expose meagerly researched issues that point towards the potential directions for further meaningful advancements. This initiative will advance a validated stance for the development of highly efficient and resilient-grid-compatible photovoltaic inverter systems by scrutinizing the integration of the DC-DC converters, proposed inverter topologies, and control design.^{1,2}

Photovoltaic (Pv) Systems And Cascaded Inverters

In solar energy conversion, the photovoltaic effect stands in the front-rank position.⁸ When sunlight strikes a semiconductor, e.g., silicon, electrons get excited by photons, producing electron-hole pairs.⁹ These charge carriers get separated by an internal electric field across the p-n junction to give a direct current (DC) output.¹⁰ This DC power is conditioned by converters and inverters for integration into the grid or load.¹⁰ The final efficiency depends on the material type used, temperature, and intensity of irradiation.¹¹ Figure 1 describes Solar Photovoltaic (PV) Power Generation.

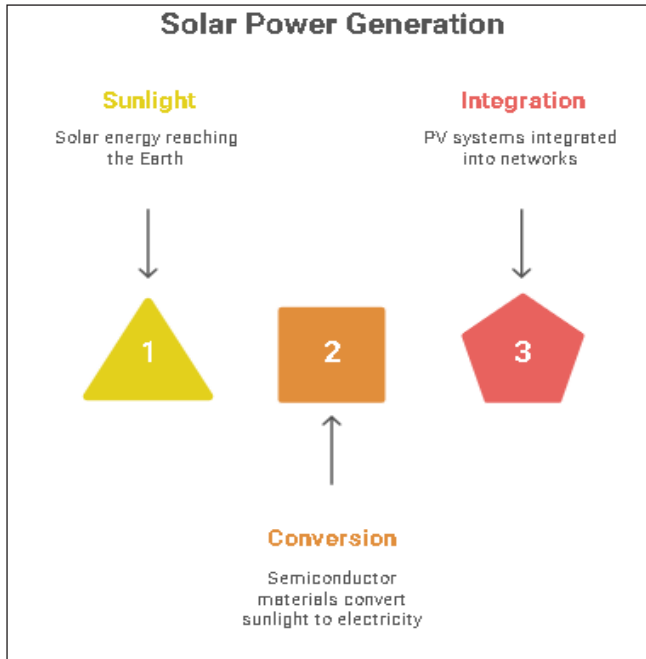

Figure 1. Solar Photovoltaic (PV) Power Generation

Solar cells or photovoltaic modules are able to convert solar energy directly into electric power by using semiconductor materials with the photovoltaic effect. Because of their cleanness, scalability, and the lowering in the cost of photovoltaic modules, they have really become the cornerstones in the renewable energy technologies.¹² Grid-connected photovoltaic systems usually consist of various components: module arrays, power electronics, and control systems. However, during operation, variations in the quality of solar irradiance and temperature will cause fluctuating direct-current voltages or currents, complicating the control of the system. In general, one key element to maximize the power extracted from a PV module is the Development of Maximum Power Point Tracking (MPPT) algorithms, which instruct a PV module to work at its best voltages or currents no matter what the irradiance conditions are.¹³

Cascaded topologies, and the cascaded H-bridge (CHB) multilevel topology in particular, are often applied within PV systems primarily in view of the disconnected or modular structure allowing a fine synthesis of high-quality AC output. Unlike the simple two-level inverters, in CHB inverters, the voltage is stepped continuously step by step, hence reducing total harmonics and contributing to a better quality of the power.¹⁴ Each power module of the inverter can receive an independent DC power source from one PV string which can give some flexibility of expansion and to an extent on fault-tolerance. However, different DC voltages within the sub-arrays due to mismatched cells, mismatched solar panels, and partial shading make the inverter cells in the cascaded structure unbalanced. This

unbalance has a direct impact on the restraint of harmonics, lowered operational efficiencies, and additional stress on power switches.¹⁵

In addressing these obstacles, the integration of buck-boost DC-DC converters with cascaded inverters has drawn interest. Buck-boost converters (implementing the Voltage Regulation) operate each PV submodule at its maximum power output while maintaining the voltage that is being supplied to the inverter cell, thereby mitigating the effects of irradiance variability.¹⁶ Far beyond, with the employment of advanced control strategies, operation coordination can be realized for handling unbalanced DC-link voltages and maintaining constant AC output for a number of cascaded inverters and converters. The conglomerate of cascaded inverters and DC-DC converters thereby ensures that the system becomes even more reliable in terms of power quality and disturbance handling by grid fluctuations. Figure

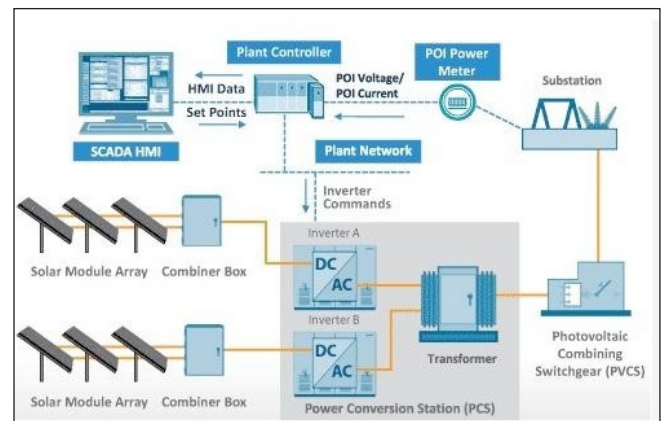

Figure 2. Photovoltaic System Architecture
2 describes Photovoltaic System Architecture.

Buck–Boost Converter Topologies

A dual iteration strategy based on the one-diode model (ODM), operating only with three measured points, was found to produce fitting of I-V curves with remarkable accuracy in the low irradiance range while lacking a complete validation in dynamic conditions.¹ Likewise, a hybrid adaptive JAYA–DE method, utilizing SDM/DDM parameters, solved multiple test cases with very low RMSE values, meaning high precision, although this was limited to static conditions.² A fractional-order dynamic PV module model with a boost converter implemented through a data-driven Levenberg-Marquardt least-squares fit enjoyed rigorous fitting under dynamic irradiance, with only a limited number of validation-test sets.³ The application of optimization techniques to both double- and triple-diode models realized faster convergence and fitting as against other meta-attempts, but remained tied to offline I-V modeling.⁴ An advanced approach to swarm optimization-based algorithms for SDM, DDM, and full PV module models

minimized convergence time and fit errors but still await validation under field-variable irradiance.⁵ Dynamic discrete equivalences modelled in a simulation setting showed much better generalization capability of meta-heuristic algorithm id parameter estimates under multiconditions as compared to ordinary least squares; however, the study was conducted against a certain type of modules.⁶ Rat-swarm optimizer attacks on MODM/MTDM parameter estimation showed better performance than many other swarm and population-based algorithms yet fall prey to trap trouble.⁷ Hybrid ARIMA-neural network combinations displayed a good prediction of energy yield, implying an

RMSE and MAPE that would not deteriorate rapidly where sunlight got a bit cloudy or quickly changed across the irradiance time.⁸ Seasonal solar-irradiance forecasting on the basis of linear and other models (SARIMAX, SVR, and LSTM) produced significant R², but their integration lacked generalized testing compatibility, demanding location-specific retraining.⁹ Plus, on comparing the open PV datasets modelled, a notable disparity in output mistakes was observed between various options as they emphasized how many offline-only techniques would not crosscheck with real-world dynamism under the fluctuating irradiance experienced on an actual scale (table 1).¹⁰

Table 1. PV Modeling & Parameter Identification Techniques

Ref	Technique Used	Results	Key Findings	Limitations
[1]	Dual-iteration ODM using three measurement points	Highly accurate I–V curve fitting at low irradiance	Minimal data requirement; strong low-light modeling capability	Not dynamically validated
[2]	Hybrid Adaptive JAYA–DE (HAJAYADE) for SDM/DDM	RMSE: 9.86×10^{-4} to 1.66×10^{-2} across 5 cases	High precision in parameter identification	Only validated under static conditions
[3]	Data-driven Levenberg–Marquardt for fractional-order dynamic PV model	Excellent match under dynamic irradiance	Demonstrated effective dynamic modeling	Limited validation datasets
[4]	Peafowl Optimization Algorithm (POA) for DDM/TDM	Faster convergence, better fitting vs. meta-heuristics	Improved accuracy for multi-diode models	Restricted to offline I–V modeling only
[5]	Improved Tuna Swarm Algorithm (ITSA) for SDM/DDM/module	Fastest convergence; reduced fitting errors	Strong optimization performance	No tests under variable real-world irradiance
[6]	Dynamic discrete equivalent model + Bat Algorithm (BA)	BA generalizes better than OLS under multiple conditions	Effective dynamic parameter estimation	Only one PV module type tested
[7]	Rat Swarm Optimizer (RSO) for MODM/MTDM	Outperformed ALO, PSO, SSA, HHO, GOA	High parameter precision; robust statistical results	Swarm-based algorithms may get stuck in local minima
[8]	Hybrid ARIMA + Neural Network for day-ahead PV forecasting	RMSE ≈ 0.9125 ; MAPE $\approx 5.9\%$	Improves prediction accuracy vs. standalone models	Weak performance under cloudy/rapid-transient irradiance
[9]	SARIMAX, SVR, LSTM for seasonal irradiance prediction	R ² ≈ 0.97 (winter), 0.96 (summer)	Performs well for seasonal forecasting	Requires location-specific retraining
[10]	PVPMC Blind Modelling benchmark dataset evaluation	Significant variation in modelling errors across systems	Highlights need for open benchmarking & standardized validation	Offline techniques cannot handle dynamic irradiance validation

Simulation Of Pv Systems Using Matlab/ Simulink Platforms

Earlier, MATLAB/Simulink modeling of a photovoltaic (PV) array linked to the DC-DC interface merged with classical Perturb and Observe (P&O) MPPT algorithm was applied to

derive various test conditions in darkness and under heat simulator, exhibiting sound convergence and enhanced output power in the converters but with no incorporation of higher reach intelligent MPPT algorithms; it is still limited to just simulation and has not been tested on real hardware.¹¹

A complete model of a PV module with a traditional P&O and MPPT exhibited a good match of I-V and P-V curves under a range of climatic conditions, showing good tracking behavior with noticeable MPP oscillations; however, the algorithm has not been tested for partial shading or rapidly changing irradiance, making generalization problematic.¹² The artificial neural network-based MPPT technique, which was trained over simulated PV datasets, showed improvement in MPPT efficiency through the reduction of continuous oscillations; the performance under the real environment is still questionable.¹³ Kinetic Gas Molecule Optimization (KGMO), an optimization based MPPT approach, proved to outperform perturb-and-observe and incremental conductance in the standard condition and partial shading, achieving higher power extraction, faster tracking, and less steady state oscillation though in terms of real-time embedded implementation, and computational feasibility were not demonstrated.¹⁴ Tests carried out on various modifications using MPPT techniques like variable step P&O and Incremental Conductance across two panel ratings in a boost-converter topology approached a common consequence of higher efficiency with possibly faster transients and lesser power loss; however, no practical verification on the hardware was performed.¹⁵ Generalized PV module models screening numerous array configurations while facing shading and

mismatch problems, analyzing losses, and showing I-V/P-V curves laid for the sake of varying variables, but there was a strong underestimation of many vital factors, such as solar radiation distribution on the cells.¹⁶ On the other side, PV-based energy systems were subjected to energy management and grid interaction assessments and resulted in many frameworks practiced: the same-level efficiency works along with immaculate power in-flow during time-domain simulations and supported by an extremely regional climate with no generalization.¹⁷ Studies supporting dynamic meteorological factors like irradiance, temperature, and wind speed, incorporated in MATLAB/Simulink to give simulation results closely matching PVsyst in terms of efficiency, power, and I-V characteristics but without any hardware validation.¹⁸ The study presented modeling of a grid-tied three-phase-low-voltage PV inverter system reflecting approximate voltage-current dependent power performances, adequate energy supply to a domestic load, without long-term stability or hardware implementations.¹⁹ Finally, a contrast in evaluation of three control techniques for MPPT under rapid changes in irradiance conditions indicated that fuzzy logic-based MPPT showed the highest tracking efficiency, also in terms of robustness and quick response, yet lacks embedded system implementation or controller operation details (table 2).²⁰

Table 2. PV Modeling and MPPT Techniques

Ref	Technique Used	Results	Key Findings	Limitations
[11]	MATLAB/Simulink PV model + Classical P&O MPPT	Stable convergence; improved output power; clear V-I and P-V curves	Efficient tracking under varied conditions	Only classical MPPT; no intelligent techniques; no hardware validation
[12]	PV module modeling + Conventional P&O MPPT	Accurate I-V/P-V curves; proper MPP tracking	Demonstrated climate-based performance variations	Not tested under partial shading or rapid irradiance changes
[13]	Neural-network-based MPPT trained on Simulink data	Higher MPPT efficiency; lower steady oscillations vs P&O	Improved MPP accuracy using NN	NN trained mostly on simulated data → risk of overfitting; limited real-world adaptability
[14]	Kinetic Gas Molecule Optimization (KGMO) MPPT	Higher power extraction; faster tracking; lower oscillations	Outperforms P&O and INC under shading	No real-time/hardware testing; computational complexity unverified
[15]	Variable-step P&O & INC + PV panel & boost converter modeling	Higher MPPT efficiency; faster transient response	Shows superiority of modified MPPT techniques	Simulation-only; ignores converter switching/thermal behavior
[16]	Generalized PV module model for array mismatches	Quantified mismatch losses; detailed I-V/P-V curves	Good analysis of array configurations under shading	Ignores irradiance distribution effects; lacks experimental validation
[17]	PV-based system with energy management strategy simulation	Efficient system-level performance; accurate power flow	Climate-specific grid-interaction strategy validation	Not generalizable across regions/grid conditions

[18]	Dynamic PV model including irradiance, temperature & wind validation vs PVsyst	High conformity with PVsyst; negligible errors	Strong simulation integrity; validated environmental effects	Validated only against software; no hardware comparison
[19]	Modeling of three-phase grid-tied PV inverter (domestic scenario)	5.1 kW load supply; stable performance; PF improvements	Good domestic grid-tied operational reliability	Case-specific; lacks long-term stability and hardware tests
[20]	Fuzzy Logic, P&O, and INC MPPT under rapid irradiance	Fuzzy MPPT: highest efficiency, robustness, fastest settling	Superior dynamic performance under fast irradiance changes	Fuzzy controller design & embedded operation not explained

Enhancement Techniques For Grid-Integrated Pv Systems

In the proposed work, an adaptive and efficient fuzzy-logic-based variable-step Incremental Conductance (INC) MPPT for grid-connected PV systems changes the INC step size according to the classification of the PV curve into regions to result in faster MPP convergence and minimal oscillation under steady-state operation conditions as compared to the case of fixed-step INC. However, these findings are largely simulation-oriented, and the establishment of the fuzzy-logic rule base depends on capturing unavoidable measurement noise and modeling inaccuracies.²¹ A preconditioned variable-step INC MPPT method was found to be well-performing in high efficiency (~99.73%-99.84%) even under low levels of solar radiation at very short settling times in smaller laboratory setups. The credibility was untested in the case of massive PV²² arrays or under no partial shading. Model-predictive control with MPPT from per-module level combined with finite-control-set model-predictive current control (FCS-MPCC) in the inverter outperforms classical PI control in terms of dynamic performance and transient response, reduces steady-state error, and improves disturbance rejection. However, precise prediction modeling requirements contribute to higher computations and may hinder real-time implementation.²³ The GWO-PSO-based hybrid algorithm for MPP tracking under partial shading conditions afforded superior speed and success in comparison to standard P&O, GWO, and PSO schemes; however, the performance of the selected schemes under real-time embedded implementation constraints is questionable because of computational and parameter flow.²⁴ The AOA-optimized PI-Incremental-Conductance (PI-IC) controller outperformed other non-optimized variants and metaheuristic searches with respect to rise and settling times, but with a lack of any practical application it is considered proof of viability in simulations, no account has been given to study converter interaction, real-world noise, and grid faults.²⁵ Nonlinear integral-backstepping (IBS) control was used for the enhancement of MPPT along with power factor correction, yielding a regulation close

to unity in power factor, reduced distortion in transient current, and steadiness with varying irradiance levels, but design of the complex controller, and other control inputting remained challenges for real-time embedded systems.²⁶ A fuzzy-logic MPPT controller with membership functions had been optimized by the MSSA and showed exceptional levels of efficiency, around 99.7%, with faster tracking and less power fluctuation. On the downside, however, experimentation and validation suffer, and in case of any changes in system parameters in the future, a further tuning may be necessary.²⁷ When fuzzy logic was combined with sliding-mode control based on a PI controller for the AC side with PSO and GA tuning and DC-side MPPT to yield performance convergence (~0.06s) and efficiency tracking (~99.86%), with THDs in the range of 8.33–10.63%, I gave evidence that further work is needed for refinements on an alternative control setup for real-time use.²⁸ The forecasting capability of a hybrid TCN/GRU deep-learning ensemble model for short-term PV power targeting a very low RMSE and MAE with a high R², helps smooth grid interconnection, although performance would decline under such events as weather transients and the generalizability of the model across sites would not be possible without retraining.²⁹ Eventually, the fractional open-circuit voltage (FOCV) MPPT algorithm and a series of tests called HIL showed promising dynamic response and tracking performance over the classic FSCC and P&O ones; however, practical implications in this regard might involve grappling with open issues such as fractional-order control convergence (table 3).

Impact Of Unbalanced Grid Conditions

Inverter performance is greatly influenced by the imbalances in power parameters, introduced by either asymmetry of the load or faulty or irregular arrangements of the distribution network.¹⁹ This phenomenon will give rise to unequal magnitudes and phase angles of the voltages, which in turn will result in distorted output currents, out-of-phase component vectors, and destabilizing temperatures within inverter components. These issues must be ameliorated to support high-quality power, operational stability, and

reliable power injection from grid-connected solar PV systems.²⁰

Voltage Unbalance Effects

In a three-phase mesh, voltage unbalance could occur due to differences in the size and the phase displacement of the line voltages, producing negative-sequence and zero-sequence components, and affecting current flow in the grid. For grid-connected PV inverters, this unbalance produces double-frequency oscillations in the DC-link voltage, which

can have a profound effect on the inverter efficiency and stability.²¹ Damage or even destruction to the power electronic devices from overvoltage or undervoltage stress can result in protective shutdown. Thus, voltage unbalance provides uneven power delivery across phases, thereby increasing harmonic distortion and thermal loading. A set of mitigating techniques targeting the minimization of the consequences for the inverter's operation and power quality is of paramount concern.

Table 3. MPPT & Control Strategies for PV Systems

Ref	Technique Used	Results (Accuracy / THD / Performance)	Key Findings	Limitations
[21]	Fuzzy-logic-based variable-step Incremental Conductance (INC) MPPT for grid-connected PV	Faster MPP convergence; reduced steady-state oscillation; improved output power vs fixed-step INC	Adaptive fuzzy rules outperform conventional INC in both dynamic and steady-state regions	Simulation only; fuzzy rule base requires manual tuning; sensitive to noise and modeling inaccuracies
[20]	Preconditioned variable-step INC MPPT validated in MATLAB/Simulink + small hardware prototype	Tracking efficiency 99.73–99.84%; settling time 10–12 ms under irradiance changes	Very fast and accurate tracking under variable sunlight conditions	Experimental validation at small scale; lacks evaluation for large PV arrays and partial shading
[23]	Hybrid MPC: module-level MPPT + finite-control-set model predictive current control (FCS-MPCC) for inverter	Fast dynamic response; low steady-state error; enhanced disturbance rejection vs PI	MPC improves inverter transient and steady-state performance simultaneously	High computation burden; requires precise predictive modeling; DSP/FPGA implementation challenges
[24]	Hybrid Grey Wolf Optimizer + Particle Swarm Optimization for GMPP under partial shading; validated in MATLAB + PSIM + buck-boost converter	Higher GMPP tracking accuracy; faster convergence; better effectiveness than GWO, PSO, P&O	Strong performance under partial shading; robust GMPP extraction	Only simulation; computational load and tuning complexity may hinder real-time implementation
[25]	AOA-tuned PI-Incremental Conductance control for 100-kW PV converter	Rise time reduced by 61%, 3%, 4.65%, 26.9% vs other methods; settling time improved by 94%, 84.7%, 86.6%, 79.3%	Arithmetic Optimization Algorithm significantly improves dynamic response of PI-IC	Simulation only; grid faults, noise, converter nonlinearities not studied
[26]	Nonlinear integral-backstepping (IBS) controller + MPPT + unity PF control for PV grid systems	Nearly unity power factor at PCC; reduced distortion under transients; stable DC-bus regulation	Strong nonlinear control maintains power quality and stable operation under load/irradiance changes	Controller complexity high; parameter tuning difficult; no hardware validation
[27]	Fuzzy-logic MPPT with membership functions optimized by Modified Sparrow Search Algorithm (MSSA)	Tracking efficiency \approx 99.7%; faster convergence; reduced power fluctuations	MSSA significantly improves fuzzy MPPT stability and accuracy	MSSA must be re-run when PV or converter parameters change; lacking experimental validation

[28]	Hybrid fuzzy–sliding-mode MPPT + PSO/GA-tuned PI for AC-side inverter control	MPPT convergence ≈ 0.06 s; tracking efficiency 99.86%; THD $\approx 8.33\%$ (PSO), 10.63% (GA)	Very fast MPPT and good tracking efficiency	THD remains high ($>5\%$); requires filters or improved control for grid compliance
[29]	Hybrid TCN/GRU deep-learning ensemble for short-term PV forecasting and smoothing	RMSE 0.0195, MAE 0.0128, R^2 0.9972	Highly accurate PV output forecasting enables smoother inverter/grid operation	Generalization weak under unusual weather; retraining required for new locations
[30]	Fractional open-circuit voltage (FOCV) MPPT; real-time HIL using dSPACE	Faster dynamic response vs FSCC & P&O; improved tracking in real-time tests	Fractional MPPT shows strong real-time stability	HIL only; lacks full-power inverter hardware testing and long-term grid validation

Current Injection and Power Quality Issues

Unbalanced grid voltages can lead to asymmetrical current injection into the distribution grid due to PV inverters. This significantly increases total harmonic distortion (THD) and reactive power variations. Such irregular current injections may result in the warming of transformers, escalated losses and even risks pertaining to potential resonance issues for distribution lines. Thus, if inverters do not account for unbalance-related conditions, they can be sources of voltage flicker, harmonic addition, and under-power factor causing harm to sensitive loads and neighboring equipment as well.²² Given such adverse impacts due to current injection under unbalanced conditions, the provision of savour from grid codes, as well as the maintenance of stability, reliability, and cost-efficiency, is essential from the esteem of establishing a grid-connected PV system. The beneficial incorporation of advanced control strategies, including dual-vector control, predictive compensation, and adaptive calculation of current reference, would abridge these consequences.²³

Integration Of Buck–Boost Converters With Cascaded Inverters

Cascading buck-boost converters with cascading PV inverters aims to keep a tight check on the voltage, extract the power to the max, and cope with the DC sources which are off-balance. Independent control of each PV submodule makes them a key element to regulate critical operation parameters in fluctuating insolation and shading conditions. This would facilitate increased system efficiency and robustness.²⁴ This integration toward power-conditioned-source control with synchronized cascaded topologies is considered mandatory in maintaining power quality within the grid-connected multilevel inverter systems.²⁵

Single-Stage Approaches

Single-stage approaches better connect the inverter to each PV module or sub-array by adding a buck boost converter unit. This enables each module to be regulated in respect to

voltage and maintained near its maximum power point to increase energy harvesting under non uniform radiation.²⁶ The single-stage configurations provide the advantage of reduced system complexity compared to multi-stage designs, while achieving faster dynamic response. An increased challenge does not lie in DC voltage imbalances, but rather with increased control requirements for coordinating the multiple inverters across the system. Although these limitations of operation exist, single-stage buck boost is further implemented within modular PV applications because of its high efficiency, fewer components, and maintenance of balanced operation of the multilevel inverter.²⁷

Multi-Stage Approaches

In a typical multi-stage approach, the connection of PV modules to cascaded inverter is carried out through an additional conversion stage, in general involving a buck-boost/boost converter—or both—and an intermediate DC–DC stage. This method of topography makes voltage regulation to certain levels more precise, thereby controlling reactive power well and dealing with harmonic distortion.²⁸ Multi-stage systems particularly prove to be efficient under harsh partial shading or highly unbalanced grid conditions because they can leave the interference at other stages of power flow optimization for each one. However, this adds complexity, cost, and more potential energy loss under various inefficiencies due to multiple conversion steps, causing advanced controller designs necessary to harmonize the system states between the different stages while trying to keep system efficiency and power quality as required in such multi-stage PV inverter configurations.²⁹

Challenges and Open Research Issues

Even though significant developments are achieved in cascaded PV Inverter systems and photovoltaic inverter systems with and without buck–boost converters, several challenges and research questions remain. The first challenge

concerns the efficient handling of the variable irradiation and partial shading, hence generating different DC-link voltages while lowering energy extraction efficiency. From the viewpoint of currently operational MPPT algorithms, chiefly the conventional P&O and Incremental Conductive algorithms, these algorithms, in many cases, diverge in slow convergence, steady-state oscillations, or the lack of adaptability towards fast-changing environmental conditions. On the other hand, intelligent and hybrid algorithms like those using fuzzy logic, artificial neural networks, swarm optimization, and model-predictive control among other promising technologies still face restrictions for their practical implementation on hardware. This restriction is due to the high computational complexity, sensitivity to parameter variations, and the need for precise modeling.³⁰

The issues to deal with are grid-related power quality disturbances as an imbalance in voltage and current will result in distortion, while other factors including absence of power and thermal stresses upon components will decrease system reliability and compliance with codes of practice.¹⁹ Higher level control techniques such as negative sequence mitigation, dual-vector control, and predictive control definitely need further adjustments based on large-scale applications.

System scalability and modularity are presented by yet another research gap. Coordination of multiple converters in a single-stage or multi-stage configuration would tend to require tight synchronization and communication schemes in order to control and reduce equivalent stress on the converter as much as possible coupled with the best balancing of the DC voltage.²⁰ Multi-stage configurations improve the quality of the voltage received from the converter but need more attention in designing the systems to address the issues needing to be critically considered so that conversion loss, cost, etc., do not rise altogether in the form of possible disadvantages.

It also failed to follow some important developments such as dynamic testing and hardware validation in existing literature. Many studies relied primarily on MATLAB/Simulink or PVsyst simulation, while real-world performance, long-term stability, and reliability in differing climatic and grid conditions remained open-ended questions. Another important opportunity in system resilience points towards the integration of energy storage, predictive load management, and advanced fault-tolerance versions.

Conclusion and Future Work

In this review, various techniques are studied, and the highest accuracy in PV system modeling, MPPT performance, and inverter control is achieved by hybrid and intelligent algorithms. Techniques based on fuzzy logic, neural networks, swarm-based optimization, and model predictive control

do a better job in MPPT over P&O and IncCond methods, showing quicker convergence and reduced steady-state perturbations. Symphony buck-boost cascaded inverter systems play a special role in dc link voltage regulation, control at the bridge level, and complete harvesting capability under varied irradiation and practical shading conditions. The integration of a single-stage structure should simplify the system and improve the dynamic response while keeping the multi-stage structures progressive in their function: voltage balancing, harmonic mitigation, adaptivity to a harsh environment, grid excursion, and more. Despite these improvements the challenges continue to exist, especially those associated with unbalanced grid conditions; current injection, harmonics, and thermal or electrical stresses on the inverter components. Numerous studies are simulation-centric, which limits real-world validation, old-term stability analysis, and scalability assessment. The practical productization of intelligent MPPT algorithms and multi-stage converter topologies requires robust embedded implementations, adaptive control strategies, and resilient designs that can survive dynamic environmental and grid context fluctuations. Open research directions would include the development of lightweight, highly adaptable, and hardware-verified maximum-power-point-tracking (MPPT) methods as well as advanced energy management strategies; a comprehensive experimental setup would be a requirement for large-scale PV systems. Therefore, resolving these issues is key to operational levels of efficiency, robustness, and reliability for PV inverter schemes. These systems will allow for a stable utility-grid connection, the maximal extraction of power, and higher power levels under various-grid conditions. Such formal advancements will not facilitate practical implementation of cascaded-PV-inverter-buck-boost-converter-integration systems into contemporary systems of renewable energy.

References

1. W. Long, T. Wu, M. Xu, M. Tang and S. Cai, "Parameters identification of photovoltaic models by using an enhanced adaptive butterfly optimization algorithm," *Energy*, vol. 229, Aug. 2021. doi: 10.1016/j.energy.2021.120750.
2. J. Dang, "Research on the parameter identification of PV module based on fuzzy adaptive differential evolution algorithm," *Energy Reports / Renewable Power Generation*, 2022.
3. Z.-Q. Wu, C.-Y. Liu, D.-L. Zhao and Y.-Q. Wang, "Parameter identification of photovoltaic cell model based on improved elephant herding optimization algorithm," *Soft Computing*, vol. 27, pp. 5797–5811, Feb. 2023. doi: 10.1007/s00500-023-07819-4.
4. G. Moustafa, "Parameter Identification of Solar Photovoltaic Systems Using an Augmented Subtraction-Average-Based Optimizer," *Energies*, vol. 4, no. 3, 2023.

5. F. Sapundzhi, "Predictive Modeling of Photovoltaic Energy Yield Using an ARIMA Approach," *Applied Sciences*, vol. 14, no. 23, 2024.
6. M. Abumohsen et al., "Hybrid machine learning model combining of CNN-LSTM for solar power generation forecasting," 2024.
7. D. Salman, C. Direkoglu, M. Kusaf et al., "Hybrid deep learning models for time series forecasting of solar power," *Neural Computing & Applications*, vol. 36, pp. 9095–9112, 2024. doi: 10.1007/s00521-024-09558-5.
8. A. Ajay Rathod, "Efficient approach for optimal parameter estimation of PV using Pelican Optimization Algorithm," 2024.
9. R. Chen, S. Gao, Y. Zhao, D. Li and S. Lin, "A hybrid model based on the photovoltaic conversion model and artificial neural network model for short-term photovoltaic power forecasting," *Frontiers in Energy Research*, 2024.
10. H. M. Ridha, H. Hizam, S. Mirjalili, M. L. Othman, M. E. Ya'acob, and M. Ahmadipour "Parameters identification of PV solar cells and modules using ...," *IET Research*, vol. [volume], Sept. 2024.
11. S. Ghoshal et al., "Modelling of PV array with DC-DC interface using P&O MPPT in MATLAB/Simulink," 2021.
12. M. L. Swarupa et al., "Simulation analysis of PV module with P&O MPPT using MATLAB/Simulink," 2021.
13. R. Sharmin et al., "Neural-network-based MPPT using Simulink-generated data," *arXiv preprint*, 2021.
14. S. Revuru and T. Rathinam, "Kinetic Gas Molecular Optimization for MPPT in PV systems," in *Proc.* 2022.
15. D. Khodair et al., "Comparative evaluation of modified MPPT techniques using MATLAB/Simulink," *Energies*, 2023.
16. V. Jha et al., "Generalized PV modeling and configuration evaluation under shading," 2023.
17. T. Hai et al., "Simulation-based performance evaluation of PV-grid energy management," 2023.
18. M. Nfaoui et al., "Modeling and validating PV performance with dynamic parameters in MATLAB/Simulink," 2024.
19. M. U. Akhtar et al., "Grid-tied PV inverter modeling for household case study," 2024.
20. N. Zhani et al., "Comparative study of fuzzy and classical MPPT control in MATLAB/Simulink," 2024.
21. M. N. Ali, K. Mahmoud, M. Lehtonen, and M. M. F. Darwish, "An Efficient Fuzzy-Logic Based Variable-Step Incremental Conductance MPPT Method for Grid-Connected PV Systems," *IEEE Access*, vol. 9, pp. 26420–26430, 2021.
22. I. Owusu-Nyarko, M. A. Elgenedy, I. Abdelsalam, and K. H. Ahmed, "Modified Variable Step-Size Incremental Conductance MPPT Technique for Photovoltaic Systems," *Electronics*, vol. 10, no. 19, art. 2331, 2021.
23. Y. Zhao, A. An, Y. Xu, Q. Wang, and M. Wang, "Model Predictive Control of Grid-Connected PV Power Generation System Considering Optimal MPPT Control of PV Modules," *Protection and Control of Modern Power Systems*, vol. 6, art. 32, Oct. 2021.
24. S. Chtita, N. Moubayed, A. A. Mohamed, and J. M. Guerrero, "A hybrid grey-wolf–particle-swarm-optimization based maximum power point tracking for photovoltaic systems operating under partial shading conditions," *Scientific Reports*, vol. 12, 2022.
25. M. A. E. Mohamed, S. N. Ahmed, and M. E. Metwally, "Arithmetic optimization algorithm based maximum power point tracking for grid-connected photovoltaic system," *Scientific Reports*, vol. 13, art. 5961, Apr. 2023.
26. S. Saleem, M. Farhan, S. Raza, F. G. Awan, A. D. Butt, and N. Safdar, "Power Factor Improvement and MPPT of the Grid-Connected Solar Photovoltaic System Using Nonlinear Integral Backstepping Controller," *Arabian Journal for Science and Engineering*, 2023.
27. T. Hai, M. Aksoy, and K. Nishihara, "Optimized MPPT Model for Different Environmental Conditions to Improve Efficacy of a Photovoltaic System," *Soft Computing*, vol. 28, pp. 2161–2179, 2024.
28. L. Zaghba, A. Borni, M. K. Benbitour, M. Debbabi, and R. H. El-Hadjoui, "Enhancing Grid-Connected Photovoltaic System Performance With Novel Hybrid MPPT Technique in Variable Atmospheric Conditions," *Scientific Reports*, vol. 14, art. 8205, 2024.
29. X. Xiang, Y. Liu, Y. Zhang, and J. Sun, "Short-Term Photovoltaic Power Forecasting Based on a Hybrid Temporal Convolutional Network/GRU Deep-Learning Model for Grid Integration," *Scientific Reports*, vol. 14, 2024.
30. C. B. N. Fapi, P. Wira, M. Kamta, and B. Colicchio, "Simulation and dSPACE Hardware Implementation of an Improved Fractional Short-Circuit Current MPPT Algorithm for Photovoltaic Systems," *Applied Solar Energy*, vol. 57, no. 2, pp. 93–106, 2021.